

Gerd Kaufmann
A. Eberle GmbH & Co. KG, Germany
gerd.kaufmann@a-eberle.de

OSJETLJIVOST DETEKCIJE ZEMOLJOSPOJA U KOMPENZIRANIM SUSTAVIMA

SAŽETAK

Detekcija visoko impedancijskih zamljospojeva je tema razmatranja kod svih tretmana uzemljenja neutralne točke u elektroenergetskim sustavima. Učestalo je mišljenje da je detekcija kvara za kompenzirane mreže sa prigušnicom za gašenje luka (ASC) prekomplikirana. Ovim člankom htjelo se pokazati da je jednostavnija i puno osjetljivija u usporedbi s ostalim tretmanima neutralne točke. Pitanje je koju osjetljivost možemo očekivati posebno kod klasičnih metoda detekcije kvara kao što su wattmetrička ($\cos\phi$), admitancijska i tranzijentna metoda. Ovaj referat daje osnovni pregled metoda detekcije i dosega osjetljivosti koji se mogu očekivati te zahtjeve za to. Kako bi detekcija kvara trebala raditi samo sa prirodnim signalima, metode s injekcijom umjetno dodanih signala nisu dio ovog članka. Potrebna točnost signala na mjernim ulazima za različite metode također će se razmatrati.

U referatu uspoređujemo osnovne aspekte praktičnim izvođenjem mjerenja za vrijeme zemljospnih proba u kompenziranim sustavima sa zračnim vodovima. Probe zemljospja su se provodile u Litvi na 10 kV sustavu, a impedancija na mjestu kvara bila je $> 5 \text{ k}\Omega$. U suradnji sa elektroprivredom ESO bio je testiran uređaj EOR-3D na osjetljivost u detekciji kvara. Prilikom različitih testova također se mjenjala ugođenost zavojnice za gašenje električnog luka, a učinak ugođenosti zavojnice na osjetljivost u detekciji kvara je prikazan. Referat pokazuje da klasične metode mogu postići visoku osjetljivost detekcije.

Ključne riječi: ASC, osjetljivost detekcije, visokoimpedancijski kvarovi, brzo vrijeme reakcije

SENSITIVE GROUND FAULT DETECTION IN COMPENSATED SYSTEMS (ASC)

SUMMARY

High impedance earth fault detection is always a topic for any kind of neutral point treatment in electrical power line systems. For compensated networks is the disseminated opinion that fault detection is just too difficult. We would like to show that is even simpler and much more sensitive compared to other neutral point treatments. Especially for the sensitivity of classical fault detection methods such as wattmetric ($\cos\phi$), the admittance method and the transient method, the question is what sensitivity you can expect. The paper will give a basic overview for the mentioned detection methods and their achievable sensitivity and the requirements for that respectively. Since the fault detection should work with natural signals only, methods with artificial signal injection during the fault are not part of the paper. The necessary measurement accuracy for the different detection methods will be considered as well.

We are comparing the basic aspects with practical measurements taken during earth fault tests in a compensated system with overhead lines. The fault impedance was $> 5 \text{ k}\Omega$ in the 10 kV system. The earth fault tests have been carried out in Lithuania. Together with the electrical utility ESO the device EOR-3D has been tested regarding the fault detection sensitivity. During the different tests also the detuning of the arc suppression coil was changed. The effect to the fault detection sensitivity was demonstrated as well. We will show that also classical methods can achieve high detection sensitivity.

Key words: ASC, fault detection sensitivity, high impedance faults, fast response time

1. INTRODUCTION

1.1 Fault trigger criteria in compensated systems

In a compensated system the so called Arc Suppression Coil (i.e. Petersen Coil) is connected between the power transformer neutral and ground. Its aim is to limit / compensate the fault current to a minimum. Hence the fault current is usually lower than any load current. So the current as a single trigger cannot be used for fault detection.

The fault condition is triggered via the Neutral Voltage Displacement (NVD) or zero sequence voltage (U_0). This voltage is used to trigger the single phase to ground fault detection in such compensated as well as isolated neutral networks.

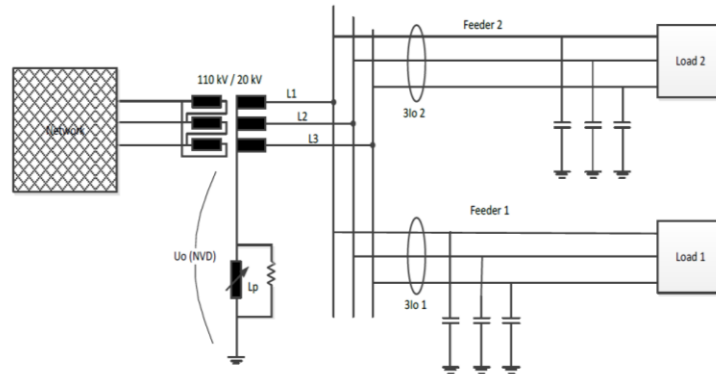

Figure 1 Arc suppression coil connected to the transformer neutral

Figure 1 can be described with the symmetrical components. Based on that theory, the picture can be divided into the positive, negative and zero sequence system. These three systems are being connected in series in case of a single phase to ground fault, the situation we would like to focus on (Figure 2).

For a compensated system the impedances in the positive and negative sequence system can be neglected. These are very small compared to the impedance of the parallel resonant circuit of the network capacitance and the arc suppression coil. This is leading to the simplified zero sequence diagram depicted in Figure 3.

The simplified zero sequence diagram in Figure 3 can be used to estimate the sensitivity. This diagram is valid if the fault detection method is based on a trigger by U_0 .

So the natural questions to ask are:

- 1) What is the right trigger level for U_0 ?
- 2) Where is the most sensitive working point?

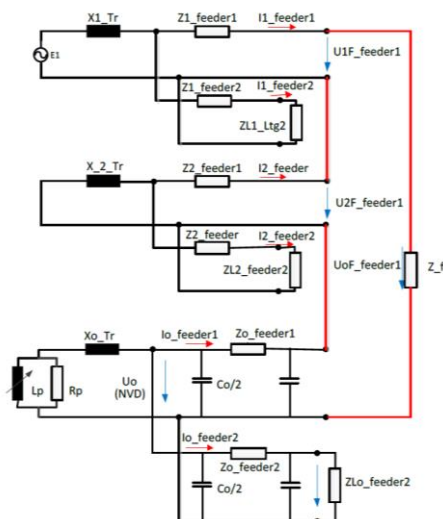

Figure 2 Symmetrical components situation with single phase to ground fault

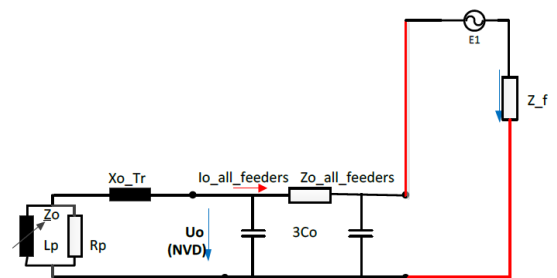

Figure 3 Simplified zero sequence equivalent diagram

1.2 Trigger level for U_0

The equivalent diagram, see Figure 3, shows the parallel resonance circuit in a compensated system. The fault impedance can be replaced with the impedance of the natural capacitive unbalance in the three phase system. That means in a system with equal line to neutral capacitances for each phase, that the unbalance current is close to zero. With a current close to zero the equivalent impedance is very high. The voltage drop over this high impedance, in a healthy network condition, leads to a very small U_0 . With increasing capacitive unbalance in the system that unbalance impedance value decreases. Hence more voltage drop is left for the parallel resonance circuit (U_0 is increasing).

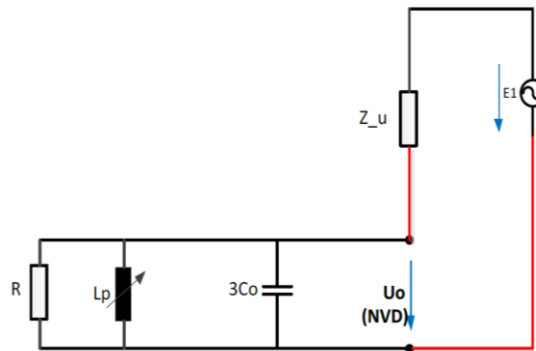
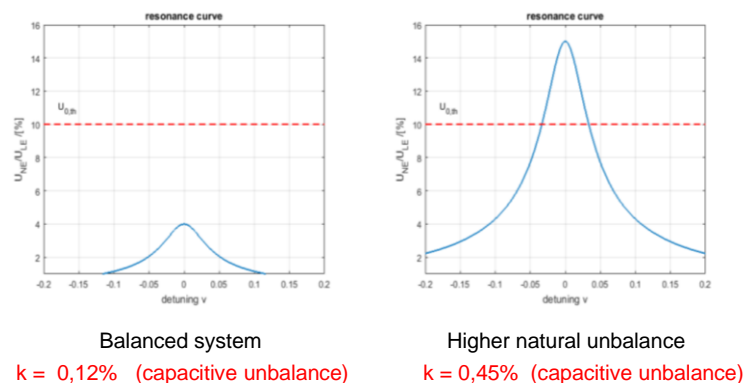

Figure 4 Equivalent zero sequence diagram for sensitivity estimation

If we call the solid fault condition the maximum unbalance in the system, the full phase voltage (E_1) drops on the parallel circuit of the arc suppression coil and the network capacitance. The impedance Z_u shown in Figure 4 is taken as 0 Ohm (earth fault).

With this equivalent diagram any condition between healthy (no single phase to ground fault) and faulty (any fault impedance) can be estimated. While tuning the arc suppression coil according to the network capacitance, the values of the natural unbalance and the damping (R) in the system are defining the peak (as well as the shape) of the resonance curve in healthy network conditions.

The trigger to distinguish between fault and normal network condition has to be set higher than this maximum voltage value. Usually the trigger level for U_0 is 30% of the nominal line to neutral voltage. For cable networks and systems with balanced line to natural capacitance, the value can be set lower (e.g 20 % or 10 % even).



Resonance curve

Common network parameters:

$I_{CE} = 100$ A (capacitive network size in A)

$d = 3$ % (wattmetric current, $I_w = 3$ A)

$U_{0,th} = 10$ % (trigger level for earth fault)

v detuning a value of 1 = 100 % detuning

negative detuning = under compensation

Figure 5 Comparing two resonance curves with different capacitive unbalance but same earth fault trigger level

To gain the highest sensitivity for the single phase to ground fault detection in a compensated system, the ideal situation would be a balanced system in terms of equal line to neutral capacitance for each phase. The trigger level for U_o could be set lower. Lower setting equals higher sensitivity.

In Figure 5 the trigger level for U_o is set to 10 %. The network with the higher capacitive unbalance will pass that trigger point during the tuning of the arc suppression coil. So for this network, the trigger must be set higher. A good value for that setting is: U_o voltage at resonance point + 10 %. In this example the trigger setting would be 25 % as an earth fault level.

1.3 Used terms and estimations in compensated systems

The value of the arc suppression coil would be technically given in mH. To compare it easier with any network capacitance it is indicated in Amper. The same is applied for the capacitance (μF) in Amper. Also the damping in the system (losses in the zero sequence system) is indicated in Amper.

The value for R (d = damping) delivers the wattmetric current during the fault condition (active component of the residual fault current). This current is not compensated by the passive inductance of the arc suppression coil. It is used to trigger the wattmetric fault detection method ($\cos\phi$) and the passive admittance method in the protection relays. The damping in the system is proportional to the network size. With the name "network size", the capacitive network size is meant – and not the dimension in km.

A typical value for the damping in a compensated network is 2% to 4 % of the capacitive current (the network size in A). So the value for the wattmetric current for a network of 100 A of capacitive current is between 2 A and 4 A. The losses of the ASC itself are around 1 % of the tuning position for new coils. This 1 % is included in the 2 % to 4 % estimation mentioned before.

1.4 Fault detection sensitivity depending on the tuning position of the ASC

The setup of the arc suppression coil has an influence on the fault detection sensitivity. Why? In fact it is a series connection of two impedances - The fault impedance and the residual impedance of the parallel circuit of the capacitance, the inductance and the losses in the network.

Using the same fault impedance, a diagram can be used to demonstrate that the highest U_o will be reached at the point of resonance. The parallel connection of the inductance (ASC) and the capacitance (network capacitance) has the maximum impedance – ideally infinity. Just the impedance of the losses (R) in the zero sequence system are remaining (Figure 6). Any detuning of the arc suppression coil will lead to a lower impedance of the parallel resonance circuit and hence a lower value for U_o = lower sensitivity. The diagram in Figure 7 shows the resonance curve with a fault impedance of 1 kOhm for the example network of 100 A capacitive current and 3 % damping.

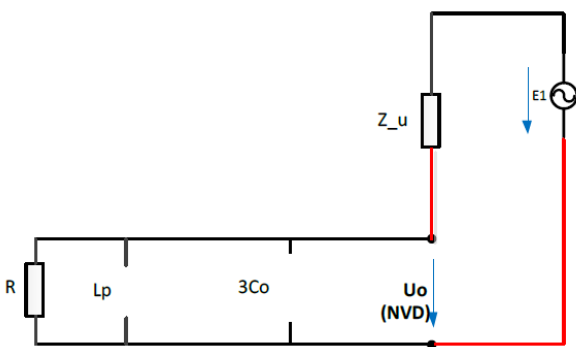

Figure 6 Equivalent diagram at the point of resonance

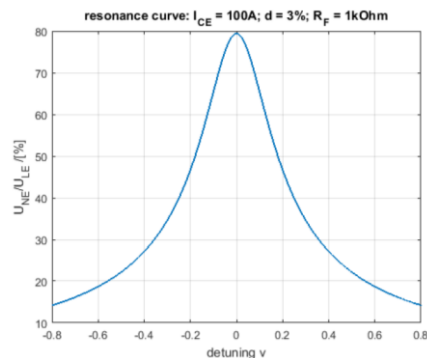

Figure 7 Changing the ASC tuning position during an earth fault with 1 kOhm fault impedance

The detuning is varied between -80 %, 0% and 80%. The voltage U_o follows a resonance curve as well.

Only for a solid fault (0 Ohm fault impedance) this value is 100 % (U_o) independent of the tuning position. Any other fault impedance than 0 Ohm will show a shape of a resonance curve already.

A proper tuning guarantees higher fault detection sensitivity.

1.5 Fault detection sensitivity depending on the capacitive network size

A growing capacitive network size (capacitive current) means growing losses in the zero sequence system. Higher losses lead to a higher wattmetric current in the system. Hence the equivalent impedance for these increasing losses must decrease.

For the following examples the assumption is a balanced system (balanced line to neutral capacitances).

Remark: Using an additional resistor to add additional damping in the system will simply reduce the impedance of the parallel resonance circuit. Lower impedance will decrease the fault detection sensitivity. The lower the resistance for the damping resistor, the lower the sensitivity to reach a certain U_0 trigger level for the same fault impedance.

Example 1:

The capacitive network size is 100 A in a 20 kV system and the losses are 3 % - a wattmetric current of 3 A remains. With the line to neutral voltage of 11.5 kV (E1), the impedance for these 3 A is 3.8 kOhm. If the coil is properly tuned to the resonance, a fault impedance of the same value of 3.8 kOhm will lead to 50 % U_0 (NVD).

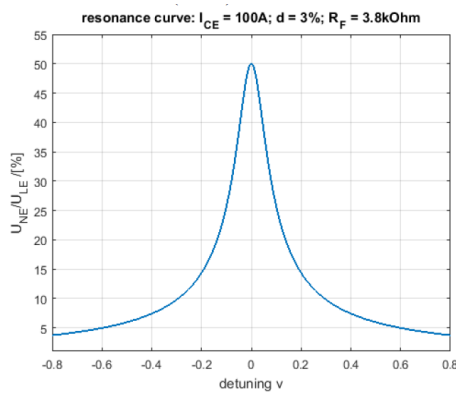

Figure 8 U_0 value for a 3.8 kOhm fault impedance vs. detuning of the ASC; network size 100 A

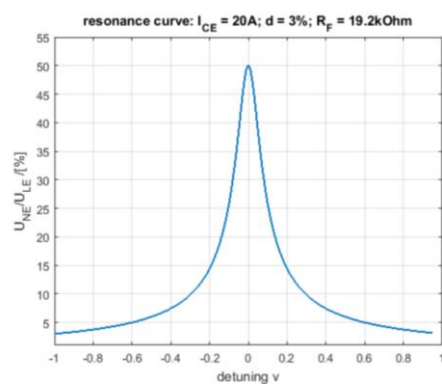

Figure 9 U_0 value for a 19.2 kOhm fault impedance vs. detuning of the ASC; network size is 20 A

Figure 8 shows that in a capacitive network size of 100 A fault impedances of 3.8 kOhm can be detected with proper tuning. Assuming the trigger level for U_0 is set to 25 %, even higher impedances can be triggered.

Example 2:

Reducing the network size to 20 A capacitive current with the same assumption of 3% remaining wattmetric current, the current is 0.6 A. These 0.6 A have an equivalent impedance of 19.2 kOhm. So for the same 50% of U_0 (NVD) the fault impedance can be 19.2 kOhm, if the system is tuned to resonance!

1.6 The fault impedance

The fault impedance values can differ depending on the power line situation. In cable systems, the fault impedance is usually very low. Typical values are between 10 Ohm and 100 Ohm. Reason is, the distance between cable core (phase) and ground (cable shield) is just a few cm. The arc itself is defining the fault impedance. In overhead line system it is of course quite different. If the conductor is falling on the ground, many single impedances are connected in parallel to a residual fault impedance. For normal grass values of >100 Ohm appear.



Figure 10 Overhead line touching the ground (gras) – parallel connection of many fault points

If a conductor is touching a tree, the fault impedances will be much higher. Depending on the type of the tree values between 5 kOhm and 8 kOhm per meter will appear (for European tree species).

2. SENSITIVITY OF DIFFERENT FAULT DETECTION METHODS

2.1 Sensitivity of the wattmetric ($\cos\phi$) fault detection method

This detection method is comparing the angle between U_0 and $3I_0$. For a healthy feeder the angle is around $+90^\circ$ (current 90° leading to the voltage).

To measure that zero sequence current ($3I_0$) a core balanced current transformer (CBCT) is used and required. The zero sequence voltage is measured via the open delta winding voltage transformers at the busbar. Since the difference between faulty feeder and healthy feeder is very small, the accuracy requirement for the U_0 and $3I_0$ measurements is very high.

For higher fault impedances, the voltage drop on the parallel resonance circuit is decreasing. Less voltage drop at the arc suppression coil leads to lower residual current. Hence the wattmetric current will be smaller. In the same way the capacitive current will be lower since the zero sequence voltage (NVD) is driving these currents. This is a linear correlation.

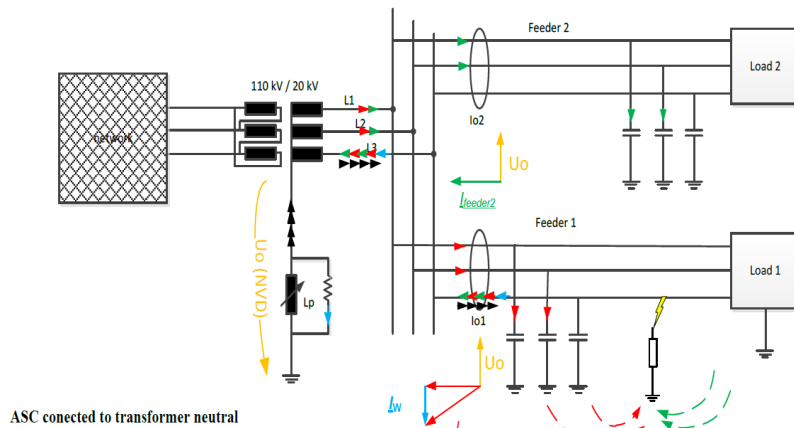

Figure 11 $3I_0$ measured in faulty feeder and healthy feeder vs. U_0

Figure 11 shows the example vectors during permanent fault condition. The angle between U_0 and $3I_0$ is $+90^\circ$ for the healthy feeder. For the faulty feeder it is a little more than $+90^\circ$ (e.g. 93°).

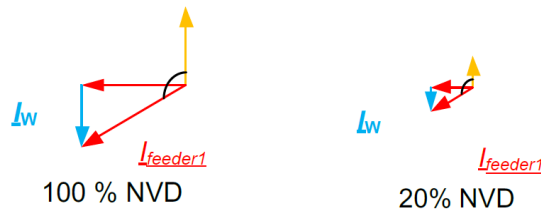

Figure 12 Vector diagram U_0 and I_0 ; low impedance fault vs. high impedance fault

Through the vector diagrams in Figure 12, it is obvious that the angle between U_0 and $3I_0$ is not changing for the same feeder setup with different fault impedances and the same network setup. So to trigger the wattmetric method, the angle information between U_0 and $3I_0$ is the key feature. At low values, the accuracy of the measurement becomes even more important. Selecting the proper measurement equipment makes it possible to detect the natural wattmetric current, also for higher fault impedances.

The trigger is still through a rising U_0 (e.g. 20% trigger value). So, the setting of the expected wattmetric current should be in the range of 20% (or less) of the expected natural wattmetric current in the system.

If we assume 500 mA residual current to be the natural wattmetric current in the system, the setting for the fault detection has to be in the range of 100 mA (primary current!). The current measured in the core balanced CT in the faulty feeder is a superimposed current of the wattmetric current, the capacitive current of the feeder and the detuning current of the arc suppression coil. So the real current for the CBCT is higher than the mentioned 100 mA for the required settings.

It is important to consider that the protection device and the measurement are not situated at the fault location. Hence the current values are much different to what might be expected by only thinking about the current at the fault location.

Also important is to use a certain time window to measure the RMS values of the wattmetric current. This method is not based on the direct sampled values. It is necessary to avoid wrong indications during the transient stage of the earth fault. Hence the indication time for the wattmetric method is between 200 ms and 1 second. This value depends on the filtering time used in different protection devices.

To point out the measurement sensitivity requirements a fault record example of three feeders shown in Figure 13 is used. The measured zero sequence currents i_{o1} and i_{o2} are for the two healthy feeders. The faulty feeder current is measured with i_{o3} . The zero sequence voltage is depicted with u_o .

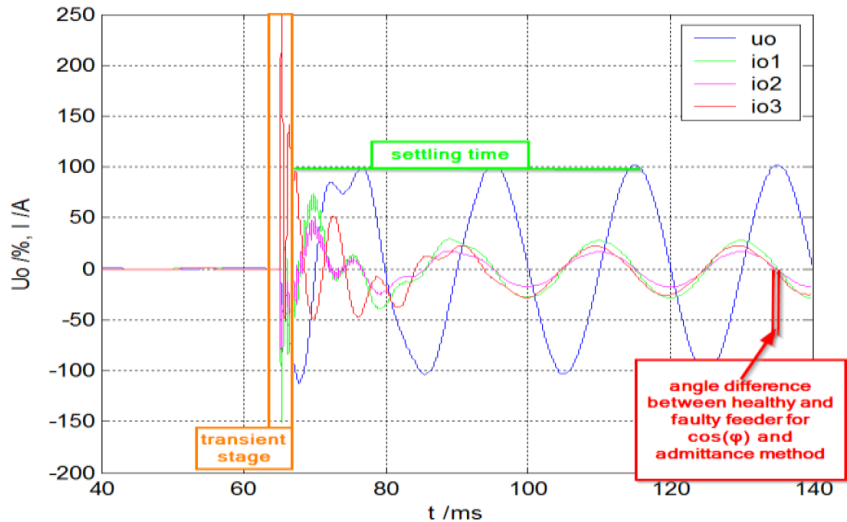

Figure 13 Very small angle difference for the wattmetric method between healthy and faulty (red) feeder

14. The indication zone for any detection / protection device using the wattmetric method is shown in Figure

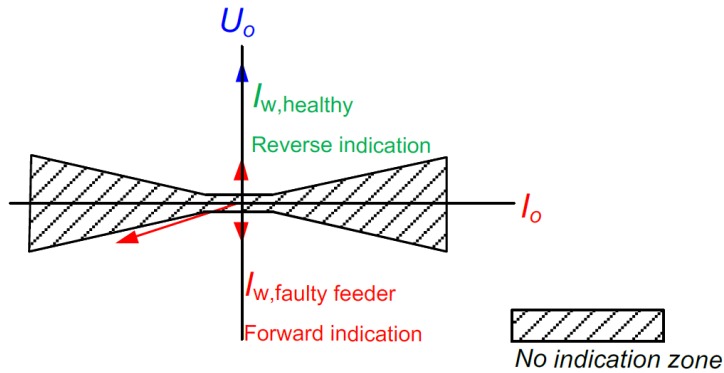

Figure 14 Indication zone for the wattmetric method

To achieve a high sensitivity, the measurement chain must be able to sense at 10 % of the nominal value with 120'' angle accuracy. This is valid for $3I_o$ but also for U_o .

2.2 Sensitivity of the admittance method

For the wattmetric method described in section 2.1, U_o , $3I_o$ and the angle information between both is used. The admittance method uses the same measurement signals. For this paper just the passive admittance method is considered. That means any admittance method without an artificial signal injection.

The equation for $\underline{Y}_o = \underline{3I}_o / \underline{U}_o$ is used. For a compensated system (with arc suppression coils), it is important to filter the active component of that admittance value to gain a higher sensitivity (this is equal to the wattmetric current in the $\cos(\varphi)$ method).

Just using the magnitude information of Y_o can cause wrong indications (especially for high sensitivity requirements). The reason is that any natural capacitive unbalance in the power grid causes an U_o and $3I_o$. Calculating the Y_o magnitude without angle consideration can lead to misinterpretation.

The active component of the complex admittance is named G . The reactive component of the complex admittance is named B . Putting the admittance diagram in the right order, a similar picture to the wattmetric indication zone appears (just a different labeling).

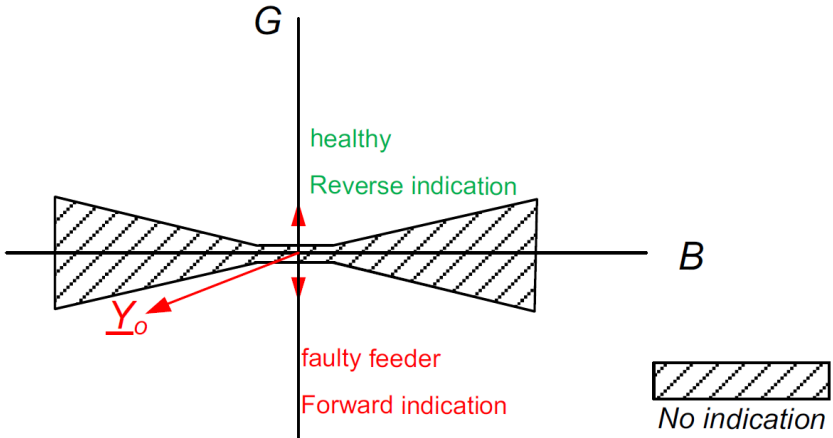

Figure 15 Admittance method indication zone

Also the admittance requires a permanent fault situation and has similar settling times like the wattmetric method.

Centralized arc suppression coils for these two methods are beneficial. Distributed arc suppression coils will lead to distributed wattmetric currents.

Provided that the same accurate measurement is used, the same sensitivity of the admittance method and the wattmetric method can be achieved!

2.3 Transient detection method

For this part two different transient methods will be compared. There are other transient methods available but they are not part of this paper.

Classical transient detection method

The so called classical transient method is using the fast process during the first 500 μs , at the beginning of the earth fault.

In the fault records displayed in Figure 16 and Figure 17 it is shown that the transient process in a compensated (as well as in an isolated system) is a high frequent process. For higher frequencies, the arc suppression coil has a higher impedance. Hence the reason, for which the transient peak current is not compensated by any existing passive compensation system. It behaves like in a power grid with an isolated neutral point.

It is essential to catch right at the trigger of U_o the sign of U_o and compare it with the sign of $3I_o$. The sign for U_o and $3I_o$ in Figure 16 is equal for the first 500 μs . This is due to the capacitive character of any healthy feeder. The faulty feeder shows a different sign for U_o and $3I_o$ (inductive behavior for the first transient peak, Figure 17).

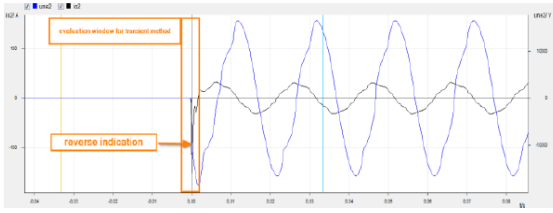

Figure 16 fault record for transient stage, reverse indication; low impedance fault

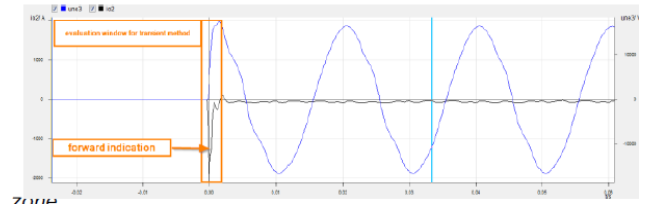

Figure 17 fault record transient stage; forward indication; low impedance fault

The angle information between faulty and healthy feeder is 180° opposite. For the transient method even phase current CT's (protection class) can be used, since the phase angle error does not matter, compared to the wattmetric and admittance method.

For low impedance faults, this transient method will work. The sensitivity is depending on the trigger settings for the zero sequence voltage. And right at the trigger, there has to be this transient process.

qu2- transient detection method

The improved transient method in the qu2 algorithm is using the integrated signal of $3I_0$ [1]. In this way it is filtering the high frequent process at the beginning of the earth fault. Integrating a current via the line to neutral capacitance is describing the charge of this capacitance. The symbol used for the charge is q . Hence the reason this algorithm is named "qu algorithm". It is comparing q_0 and U_0

The algorithm is using the features of modern digital devices. The sampled signals are stored. In case of a U_0 trigger, the device memory is used to sense for the starting point of the transient process. That enables the detection / protection device to evaluate the transient process also for high impedance faults.

According to the sensitivity basics described in chapter 1.1 , the sensitivity can reach >10 kOhm fault impedance for smaller network parts (e.g. 20 A capacitive network size with 3 % damping, 20 kV nominal voltage). Phase CT's and VT's can be used.

3. PRACTICAL TESTING OF THE TRANSIENT METHOD (QU2) SENSITIVITY



Figure 18 Test setup with EOR-3D for two feeders



Figure 19 Test site for high impedance fault

During life test in Lithuania we had the chance to proof the sensitivity of that algorithm. Even in an overhead line system with high natural capacitive unbalance.

The test setup was in a 10 kV system. The test was performed with a wooden stick (Figure 19).

Network parameter:

- Capacitive current 27 A
- Wattmetric current 1 A
- Rated voltage 10 kV
- U_0 16% (healthy condition)

The transient process is visible in the fault record in Figure 20 right at the beginning of the fault. It is depending on the trigger settings of U_0 to trigger right at that point.

In Figure 21 is depicted that the transient process itself is before the actual trigger setting in the device. The qu2 algorithm is using the internal measurement memory to search for the real transient process. This enables much higher fault sensitivity. The trigger for the expected current level is automatically adjusted according to the value of U_0 . Less U_0 (higher fault impedance) requires less $3I_0$.

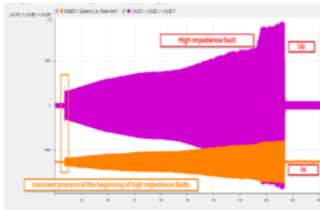

Figure 20 High impedance fault development for 200 s trigger

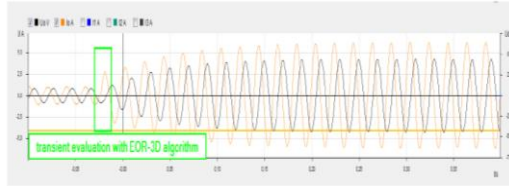

Figure 21 Transient process evaluated by the EOR-3D algorithm

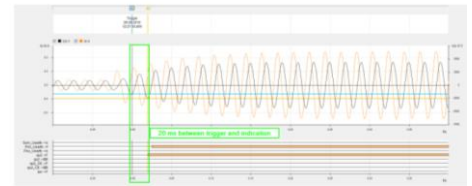

Figure 22 Response time 20 ms after U_0

Right after the trigger through U_0 in the device, the signal is sent to the relays output (Figure 22).

The setting for the zero sequence current is made via primary current values for 100 % of the zero sequence voltage. An equivalent capacitance is computed. For higher fault impedances, a lower value for U_0 will appear. According to that lower voltage, the algorithm is expecting a lower value for $3I_0$ as well. This is allowing a very high fault detection sensitivity without complicated setting adaptation.

Distributed arc suppression coils are no issue for the qu2 transient method either. Also the requirements to the measurement accuracy are very low. Phase current and phase voltage measurements can be used to compute $3I_0$ and U_0 .

Looking at the low measurement accuracy requirements, it becomes very interesting to use sensors to measure U_0 and $3I_0$. Many applications using capacitive or resistive voltage dividers to measure the phase voltages are commissioned successfully in the meantime. The picture in Figure 23 shows the example for an overhead line applicable combined sensor (voltage and current measurement). The voltage measurement is based on capacitive voltage dividers and the current is measured via a Rogowski coil. Both signals are connected to the EOR-3D for each phase.

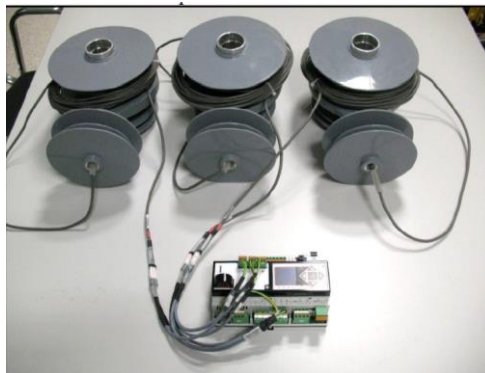

Figure 23 Overhead line combined sensor for phase voltage and current measurement connected to the EOR-3D (A. Eberle)

4. SENSITIVITY INFLUENCE OF THE ASC TUNING POSITION

During the testing also the influence of the tuning position has been compared. Three tuning positions have been tested. The Expected value for U_0 is 6 kV for a solid fault. The test impedance was computed to 5 kOhm.

- Detuning +40%
- Detuning -10%
- Detuning 0%

The response of U_0 is indicating the sensitivity.

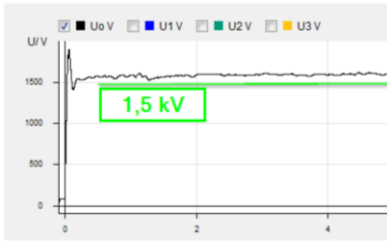

Figure 24 Detuning +40%,
5 kOhm fault impedance

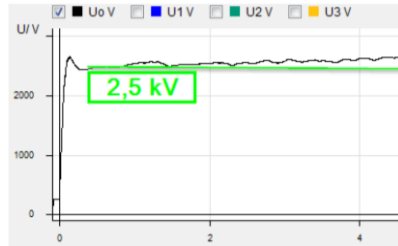

Figure 25 Detuning -10%,
5 kOhm fault impedance

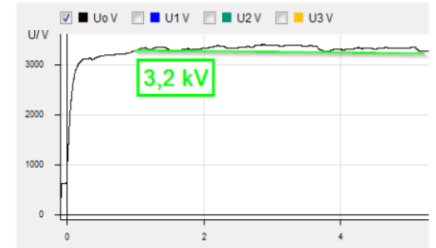

Figure 26 Detuning 0%,
5 kOhm fault impedance

It is obvious looking at Figure 26 that for the proper tuning position the value for U_o is maximum compared to the other tuning positions (Figure 24 and Figure 25). A value of over 50 % U_o could be measured. This can be used very easily to trigger such high impedance fault with a setting of e.g. 25 % U_o as earth fault level.

A value of 1.5 kV U_o (25 %) like for the +40% detuning is very close to the natural unbalance voltage in healthy network conditions (16 %). When the setting for U_o was selected to 20 %, the fault was triggered correctly. With a setting of 30% for U_o trigger, that fault was missed.

Putting the operation points into a simple Excel sheet, the resonance curve of the system for 5 kOhm fault impedance is visible. This is proofing the explanations from chapter 1.3.

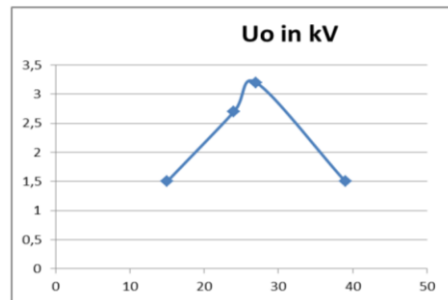

Figure 27 U_o vs. tuning position in A

The 5 kOhm fault impedance in the 10 kV system had voltage and current values comparable with a 10 kOhm fault impedance in a 20 kV system.

5. CONCLUSION

Detecting high impedance faults is a challenge in any kind of neutral point treatment in powerline systems. It was shown that the compensated system enables to detect high fault impedances for single line to ground faults with simple measures. A proper tuning of the arc suppression coil is a simple example. In a compensated system the highest sensitivity for single phase to ground faults - compared to other neutral point treatments - can be achieved.

The sensitivity of the wattmetric method and the admittance method can be taken as equal. However both require a very accurate measurement (current and voltage). Especially for overhead line systems it is beneficial to use sensitive fault detection methods. Using fault detection methods with minor requirements to the measurement accuracy (such as the qu2 algorithm implemented in the EOR-3D and EOR-D) increases the selectivity and sensitivity. Deploying detection devices along an overhead line (e.g. in auto recloser units) can lift existing technology to a sensitive earth fault detection for compensated systems. Using the qu2 transient algorithm allows using non-conventional measurement sources such as capacitive voltage dividers (voltage measurement) and Rogowski coils (current measurement).

It was shown that the transient method - using the qu2 algorithm - delivers very good results even for high impedance faults.

6. REFERENCES

- [1] 1. CIRED, 2003, Barcelona, A new directional transient relay for high ohmic earth faults, Gernot Druml, A. Eberle GmbH, Germany